



Bathtub/Whirlpool

60" x 60" x 21"

Above Floor Rough

Product Features

- + Factory plumbed, ready to install.
- + Can be installed in an island or alcove.
- + Pumps up to 60 gallons per minute with a 3/4 hp motor.
- + Eight jets, four scalloped pulse jets and four mini pulse jets.
- + High gloss acrylic surface for a brighter shine and better wear resistance.
- + Easy to install for both new construction and remodel products.
- + Covered with a protective film to maintain finish during installation.
- + Cardboard insert available for added protection. (Standard on whirlpools)
- + Factory installed inline heater available.
- + Made in USA.

Claudio

SKUs

60" x 60" x 21"
whirlpool

LSWLD_Hxx6060C-yy

60" x 60" x 21"

Color Options

(color code replaces "xx" in SKU)

- | | |
|-----------|-------------------|
| 01 White | 09 Biscuit |
| 02 Almond | 22 Black |
| 07 Silver | 30 Brushed Nickel |

Inline Heater

Factory Installed Add "H" to end of SKU.

Sold Separately HTR01

Trim Options for jets
(color code replaces "yy" in SKU)

- | | |
|------------------|-----------|
| 00 Color Matched | 01 Chrome |
|------------------|-----------|

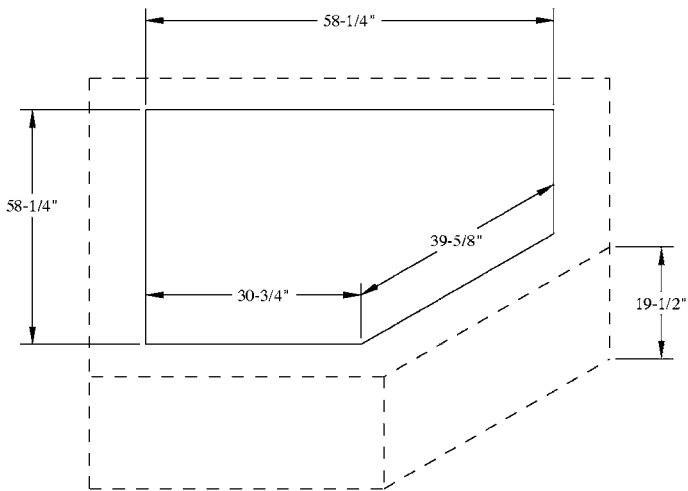
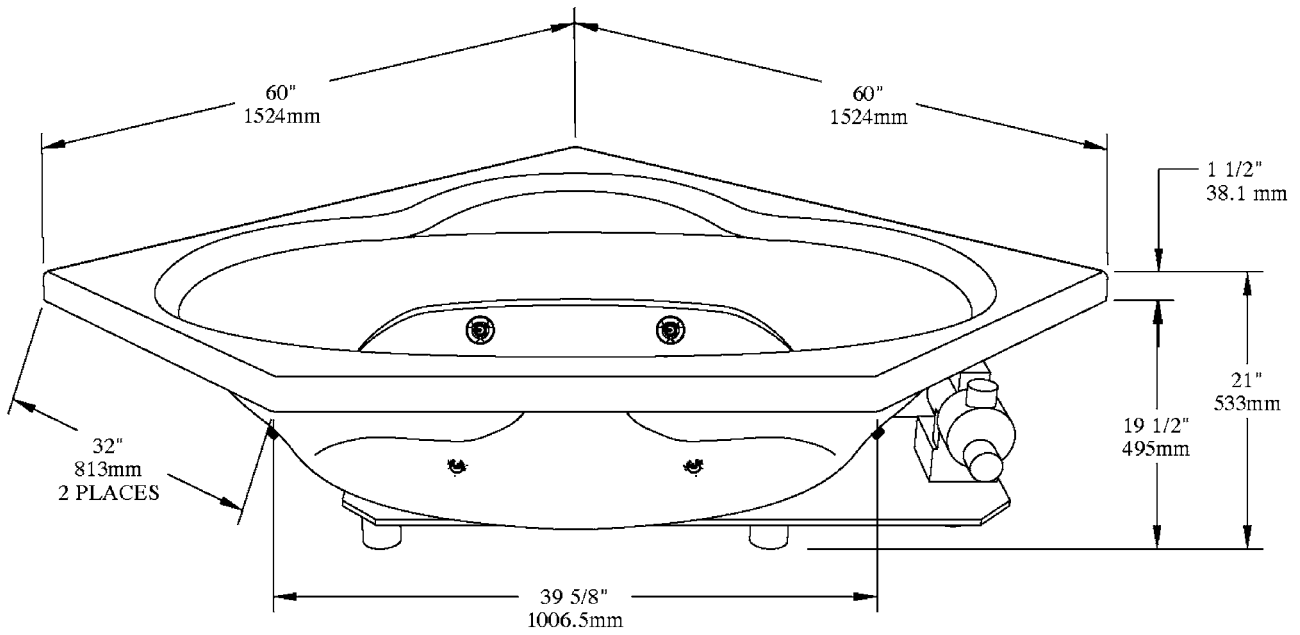

Specific island construction may vary, as long as cutout size and depth are correct. (Tub weight must be supported by feet).

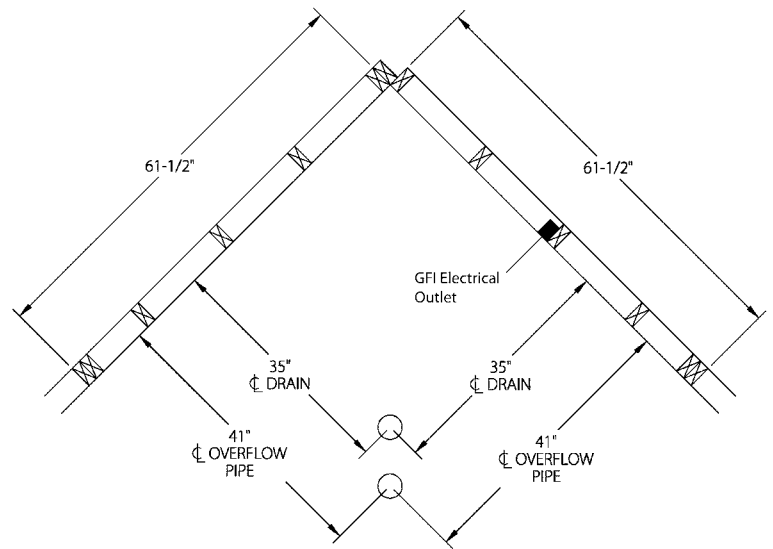

RH Installation shown - reverse for LH installation. Tile Flange Kit available for alcove installation.

Access to pump/motor required for whirlpool installation. 20 amp GFI outlet required.

⊗ = Stud location

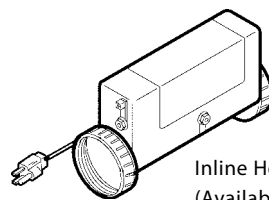

Inline Heater
(Available factory installed or sold separately, see reverse)

Lyons®
The finishing touch.